

# ■ Operating and installation instructions

REMKO RKL DC series

Local room air conditioner in split design

RKL 495 DC





**Read these operating instructions carefully before commissioning / using this device!**

**These instructions are an integral part of the system and must always be kept near or on the device.**

Subject to modifications; No liability accepted for errors or misprints!

**Translation of the original**

## Table of contents

<b>1</b>	<b>Safety and usage instructions</b> .....	<b>4</b>
1.1	General safety notes.....	4
1.2	Identification of notes.....	4
1.3	Personnel qualifications.....	4
1.4	Dangers of failure to observe the safety notes.....	5
1.5	Safety-conscious working.....	5
1.6	Safety instructions for the operator.....	5
1.7	Safety notes for installation, maintenance and inspection.....	5
1.8	Unauthorised modification and changes.....	6
1.9	Intended use.....	6
1.10	Warranty.....	6
1.11	Transport and packaging.....	6
1.12	Environmental protection and recycling.....	6
<b>2</b>	<b>Technical data</b> .....	<b>7</b>
2.1	Unit data.....	7
<b>3</b>	<b>Design and function</b> .....	<b>8</b>
<b>4</b>	<b>Operation</b> .....	<b>9</b>
<b>5</b>	<b>Installation</b> .....	<b>11</b>
<b>6</b>	<b>Connecting line</b> .....	<b>14</b>
<b>7</b>	<b>Electrical wiring</b> .....	<b>17</b>
<b>8</b>	<b>Troubleshooting</b> .....	<b>18</b>
<b>9</b>	<b>Care and maintenance</b> .....	<b>20</b>
<b>10</b>	<b>Shutdown</b> .....	<b>21</b>
<b>11</b>	<b>Exploded view and spare parts lists</b> .....	<b>22</b>
11.1	Exploded view indoor unit.....	22
11.2	Spare parts list - Indoor unit.....	23
11.3	Exploded view - Outdoor unit.....	25
11.4	Spare parts list - Outdoor unit.....	26
<b>12</b>	<b>Index</b> .....	<b>27</b>

# REMKO RKL DC series

## 1 Safety and usage instructions

### 1.1 General safety notes

Carefully read the operating manual before commissioning the units or their components for the first time. It provides useful tips and notes such as hazard warnings to prevent injury and material damage. Failure to follow the directions in this manual can endanger persons, the environment and the equipment itself or its components and will void any claims for liability.

Store this manual and the information required for the operation of this system (e.g. refrigerant data-sheet) in the vicinity of the unit.

The refrigerant used in the system is flammable. If applicable, observe the local safety conditions.



**Warning of inflammable substances!**

### 1.2 Identification of notes

This section provides an overview of all important safety aspects for proper protection of people and safe and fault-free operation. The instructions and safety notes contained within this manual must be observed in order to prevent accidents, personal injury and material damage.

Notes attached directly to the units must be observed in their entirety and be kept in a fully legible condition.

Safety notes in this manual are indicated by symbols. Safety notes are introduced with signal words which help to highlight the magnitude of the danger in question.

#### **DANGER!**

Contact with live parts poses an immediate danger of death due to electric shock. Damage to the insulation or individual components may pose a danger of death.

#### **DANGER!**

This combination of symbol and signal word warns of a situation in which there is immediate danger, which if not avoided may be fatal or cause serious injury.

#### **WARNING!**

This combination of symbol and signal word warns of a potentially hazardous situation, which if not avoided may be fatal or cause serious injury.

#### **CAUTION!**

This combination of symbol and signal word warns of a potentially hazardous situation, which if not avoided may cause injury or material and environmental damage.

#### **NOTICE!**

This combination of symbol and signal word warns of a potentially hazardous situation, which if not avoided may cause material and environmental damage.



*This symbol highlights useful tips and recommendations as well as information for efficient and fault-free operation.*

### 1.3 Personnel qualifications

The unit is supplied ready for operation; commissioning the refrigeration technology is not necessary. The unit is also suitable for stationary installation. Stationary installation that requires the connecting lines that convey the refrigerant to be disconnected must be carried out by a certified service centre.

## 1.4 Dangers of failure to observe the safety notes

Failure to observe the safety notes may pose a risk to people, the environment and the units. Failure to observe the safety notes may void any claims for damages.

In particular, failure to observe the safety notes may pose the following risks:

- The failure of important unit functions.
- The failure of prescribed methods of maintenance and repair.
- Danger to people on account of electrical and mechanical effects.

## 1.5 Safety-conscious working

The safety notes contained in this manual, the existing national regulations concerning accident prevention as well as any internal company working, operating and safety regulations must be observed.

## 1.6 Safety instructions for the operator

The operational safety of the units and components is only assured providing they are used as intended and in a fully assembled state.

- The unit is delivered ready to be used flexibly and is ready for operation after being set up by the operator.
- Stationary installation that requires the connecting lines that convey the refrigerant to be disconnected may only be carried out by authorised specialists!
- Protective covers (grilles) over moving parts must not be removed from units that are in operation.
- Do not operate units or components with obvious defects or signs of damage.
- Contact with equipment parts or components can lead to burns or injury.
- The units and components must not be exposed to any mechanical load, extreme levels of humidity or extreme temperatures.
- The system is filled with a flammable refrigerant. Never thaw any frozen unit components independently!
- Rooms in which refrigerant may escape shall be adequately aerated and ventilated. Otherwise there is danger of suffocation.
- All housing parts and unit openings, e.g. air inlets and outlets, must be free from foreign objects, fluids or gases.
- The units may not be used in environments containing a great deal of dust or chlorine, or in places with atmospheres containing ammonia.

- The units must be inspected by a service technician to ensure that they are safe to use and fully functional at least once yearly. Visual inspections and cleaning may be performed by the operator when the units are disconnected from the mains.
- The local room air conditioners are designed for flexible use in living and work spaces. Year-round operation is not recommended.
- Do not leave the units running for an extended period unsupervised.

## 1.7 Safety notes for installation, maintenance and inspection

- The refrigerant R32 used in the system is flammable. If applicable, observe the local safety conditions.
- Keep the cooling circuit clear of other gases and foreign substances. Only fill the cooling circuit with the refrigerant R32.
- Appropriate hazard prevention measures must be taken to prevent risks to people when performing installation, repair, maintenance or cleaning work on the units.
- The setup, connection and operation of the units and its components must be undertaken in accordance with the usage and operating conditions stipulated in this manual and comply with all applicable regional regulations.
- Only install and store the units in rooms larger than 4 m<sup>2</sup>. With a failure to comply, leaks may result in the room filling with a flammable mixture! The minimum room size of 4 m<sup>2</sup> required for installation and storage pertains to the basic fill quantity of the unit. This varies according to the installation type and total fill quantity of the system. The calculation must take place in accordance with valid DIN standards. Make sure that the installation site is suitable for safe unit operation.
- All persons who intervene in the cooling circuit must hold a valid certificate from the chamber of industry and commerce, which confirms their ability to work with refrigerant.
- Regional regulations and laws as well as the Water Ecology Act (WHG) must be observed.
- The power supply should be adapted to the requirements of the units.
- Units may only be mounted at the points provided for this purpose at the factory. The units may only be secured or mounted on stable structures, walls or floors.
- Interventions in the cooling circuit are only possible after completely draining the refrigerant. Never solder or grind unit components!
- Note that refrigerant may be odourless.

# REMKO RKL DC series

- Mobile units must be set up securely on suitable surfaces and in an upright position. Stationary units must be permanently installed for operation.
- The units and components should not be operated in areas where there is an increased risk of damage. Observe the minimum clearances.
- The units and components must be kept at an adequate distance from flammable, explosive, combustible, abrasive and dirty areas or atmospheres.
- Safety devices may not be modified or bypassed.

## 1.8 Unauthorised modification and changes

Modifications or changes to units and components are not permitted and may cause malfunctions. Safety devices may not be modified or bypassed. Original replacement parts and accessories authorised by the manufacturer ensure safety. The use of other parts may invalidate liability for resulting consequences.

## 1.9 Intended use

Depending on the model, the equipment and the additional fittings with which it is equipped is only intended to be used as an air-conditioner for the purpose of cooling or heating the air in an enclosed room..

Different or additional use shall not be classed as intended use. The manufacturer/supplier assumes no liability for damages arising from an unintended use of the equipment. The user bears the sole risk in such cases.

Using the equipment as intended also includes working in accordance with the operating manual and installation instructions and complying with the maintenance requirements.

Under no circumstances should the threshold values specified in the technical data be exceeded.

## 1.10 Warranty

For warranty claims to be considered, it is essential that the ordering party or its representative complete and return the "certificate of warranty" to REMKO GmbH & Co. KG at the time when the units are purchased and commissioned.

The warranty conditions are detailed in the "General business and delivery conditions". Furthermore, only the parties to a contract can conclude special agreements beyond these conditions. In this case, contact your contractual partner in the first instance.

## 1.11 Transport and packaging

The devices are supplied in a sturdy shipping container. Please check the equipment immediately upon delivery and note any damage or missing parts on the delivery and inform the shipper and your contractual partner. For later complaints can not be guaranteed.

### WARNING!

**Plastic films and bags etc. are dangerous toys for children!**

Why:

- Leave packaging material are not around.
- Packaging material may not be accessible to children!

## 1.12 Environmental protection and recycling

### Disposal of packaging

All products are packed for transport in environmentally friendly materials. Make a valuable contribution to reducing waste and sustaining raw materials. Only dispose of packaging at approved collection points.



### Disposal of equipment and components

Only recyclable materials are used in the manufacture of the devices and components. Help protect the environment by ensuring that the devices or components (for example batteries) are not disposed in household waste, but only in accordance with local regulations and in an environmentally safe manner, e.g. using certified firms and recycling specialists or at collection points.



## 2 Technical data

### 2.1 Unit data

Series		RKL 495 DC	RKL 495 DC <i>S-LINE</i>
Operating mode		Local inverter room air conditioner in split design	
Nominal cooling output <sup>1)</sup>	kW	4.30	
Energy efficiency ratio <sup>1)</sup>		B	
Energy efficiency ratio SEER <sup>1)</sup>		4.74	
Power consumption, annual, Q <sub>CE</sub>	kWh	318	
Application area (room volume), approx.	m <sup>3</sup>	120	
Adjustment range indoor unit	°C/%r.H.	+16 to +30 / 35 to 80	
Operating range outdoor unit	°C/%r.H.	+21 to +43 / 35 to 80	
Refrigerant		R32 <sup>3)</sup>	
Refrigerant, basic quantity	kg	0.97	
CO <sub>2</sub> equivalent	t	0.66	
Max. operating pressure	kPa	4200	
Air volume flow per level, indoor unit	m <sup>3</sup> /h	350/450/550	
Max. airflow volume outdoor unit	m <sup>3</sup> /h	930	
Sound press. level p. stage, ind. unit <sup>2)</sup>	dB(A)	47/50/54	
Sound power level max., IT/AT	dB(A)	57.0/62.0	
Power supply	V/Hz	230/1~/50	
Enclosure class indoor unit / outdoor unit	IP	24/X4	
Electr. rated power consumption <sup>1)</sup>	kW	1.37	
Electr. rated current consumption <sup>1)</sup>	A	5.82	
Elec. starting current max., LRA	A	8.00	
Condensate pump, flow rate, max.	mm WS	1800	
Refrigerant piping, length	mm	3000, 2300 usable	
Dimensions indoor unit H/W/D	mm	695/470/335	
Dimensions outdoor unit H/W/D	mm	490/510/230	
Weight indoor unit	kg	38.0	
Weight outdoor unit	kg	12.0	
Standard colour		white	silver
Serial number		1926...	1927...
EDP no.		1616495	1616496

<sup>1)</sup> Air inlet temperature TK 27 °C / FK 19 °C, outdoor temp. TK 35 °C, FK 24 °C, max. air flow

<sup>2)</sup> Gap 1 m free space / <sup>3)</sup> Contains greenhouse gas according to Kyoto protocol, GWP 675

# REMKO RKL DC series

## 3 Design and function

### Unit description

The unit is particularly suited for flexible operation, but can also be mounted in a stationary installation. The local room air conditioner is equipped with an indoor unit for floor installation in an indoor area, and an outdoor unit for wall or ground installation outdoors. In "cooling" mode, the output produced by the compressor precisely matches itself to requirements, and thereby regulates the nominal temperature with minimal temperature deviations. This "inverter technology" results in energy savings over conventional split systems and also reduces noise emissions to a particularly low level. The flexible connecting line serves to transport the heat to the outdoor unit. The outdoor unit discharges the absorbed heat to the outdoor air by means of a heat exchanger (condenser). The condensate collected during cooling mode is transported to the outdoor unit by means of a condensate pump integrated in the indoor unit and evaporates via the heat exchanger. The unit filters and dehumidifies the air thereby creating a comfortable room climate. It works fully automatically and offers numerous additional options thanks to microprocessor regulation. The operation of the unit can take place conveniently using the infra-red remote control included.

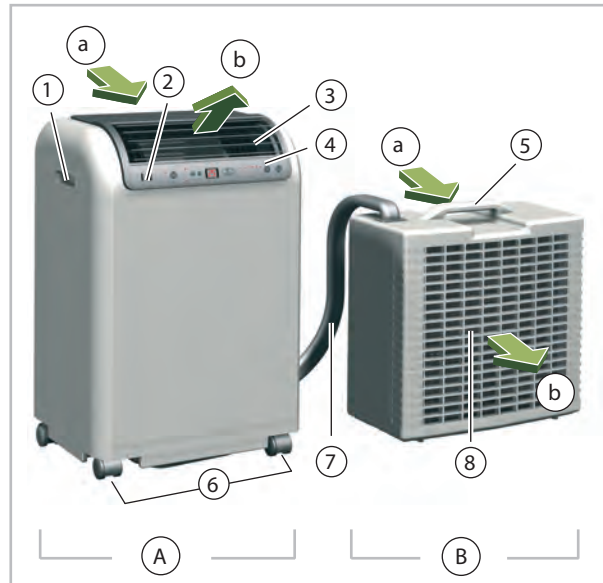

Fig. 1: Front view

- A: Indoor unit / B: Outdoor unit
- a: Air inlet / b: Air outlet
- 1: Recessed grip
- 2: Infrared receiver
- 3: Ventilation louvres
- 4: Control panel
- 5: Carrying handle
- 6: Transport castors
- 7: Connecting line
- 8: Condenser fan (rear side)

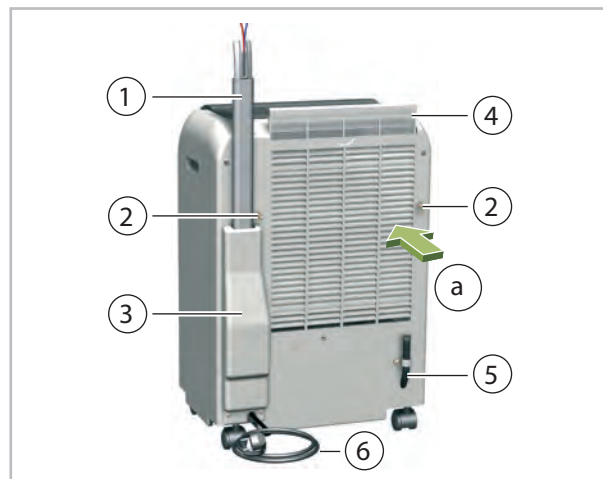

Fig. 2: Rear view (indoor unit)

- a: Air inlet
- 1: Connecting line
- 2: Mounting for the outdoor unit
- 3: Cover
- 4: Air filter
- 5: Condensate drain
- 6: Power supply with plug



## 4 Operation

The system can be operated by means of the control panel on the device or via the standard infrared remote control unit. The functional operation of the buttons among themselves is identical, however, the designation can vary. The batteries must be correctly inserted before the infrared remote control is used.

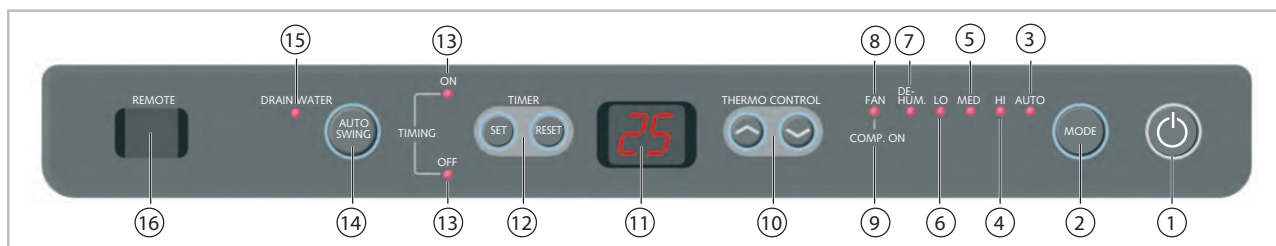

Fig. 3: Control panel

### Legend

① „**⏻**“ button

② „**MODE**“ button (Fan speed-mode)

The fan speed is indicated by means of LEDs in the selected modes AUTO-HI-MED-LO or circulated air mode FAN.

③ LED „**AUTO**“ (Fan mode)

Indication of the automatic fan operation.

④ LED „**HI**“ (Fan mode)

Indication of the high fan operation.

⑤ LED „**MED**“ (Fan mode)

Indication of the average fan operation.

⑥ LED „**LO**“ (Fan mode)

Indication of the low fan operation.

⑦ LED „**DE- HUM.**“ (Dehumidifying mode)

Indication of the dehumidifying mode.

⑧ LED „**FAN**“ (Circulated air )

Indication of the circulated air.

⑨ LED „**COMP. ON**“ (Compressor operation)

The controller controls the cooling output by means of switching the compressor on or off. Compressor operation is indicated by means of the LED. If the LED flashes, the compressor will be activated in max. 3 mins.

⑩ Button „**▼ ▲**“ Temperature setting

The desired nominal temperature can be set with the „**▼ ▲**“ buttons in steps of 1°C between 16 and 30°C.

⑪ **Display**

The display shows the set nominal temperature or the residual time of a programmed timer.

⑫ **"ON" and "OFF" timer**

The timer function can be used to switch the device on or off automatically in hourly intervals („**▼ ▲**“ buttons) by means of pressing the "SET" button. The function can be used to program the switch-on timer when the device is off and the switch-off timer when the device is on, for up to 24 hours. Both timers can be deleted by means of pressing the "RESET" button.

⑬ LED „**TIMING ON and OFF**“

Indicator of activation (LED ON) or deactivation (LED OFF) of the timing on and off

⑭ „**AUTO SWING**“ button

The direction of the discharged air via the oscillating fins can be adjusted to fixed or oscillating by pressing the "AUTO SWING" button.

⑮ LED „**DRAIN WATER**“

If the pump is unable to transport the collected condensate then this is signalled via an acoustic alarm in combination with the flashing "DRAIN WATER" LED. The device will be operational again after the container is emptied by means of the condensate drain.

⑯ **Infrared receiver**

The device receives the signals from the infrared remote control via the sensor.

⑰ „**FAN**“ button(only on the infrared remote control)

The ventilator speed can be adjusted by means of pressing the "FAN" button.

# REMKO RKL DC series

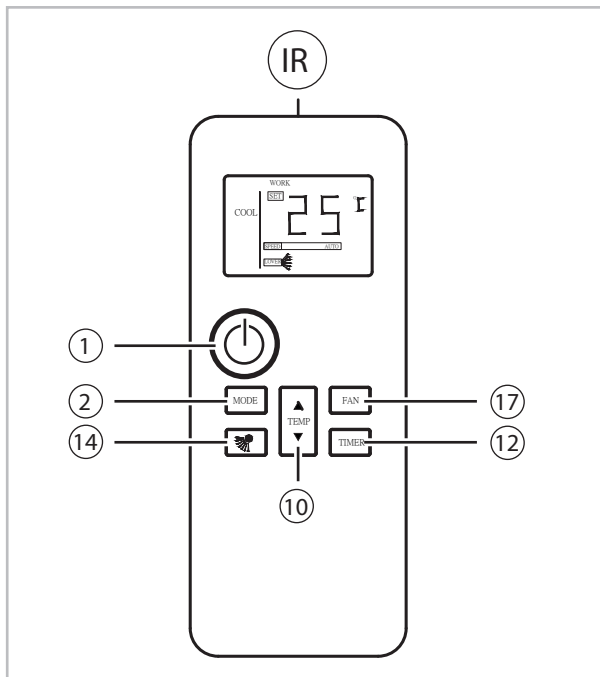

Fig. 4: Infrared remote control

IR Infrared transmitter

## Cooling mode (❄️)

1. ➤ Switch the unit on by means of the "I / 0" button.
2. ➤ Set the temperature selection switch to the desired nominal temperature.
3. ➤ Select the desired fan mode to AUTO, HI, MED or LO by means of the "MODE" button.

## Circulated air mode (🌀)

1. ➤ Switch the unit on by means of the "I / 0" button.
2. ➤ Select FAN mode by means of the "MODE" button.

The outdoor unit can remain in the room in circulated air mode. However, do not hang the outdoor unit onto the indoor unit.

## Dehumidifying mode DE-HUM.

Position the indoor unit and the outdoor unit in the room that is to be dehumidified.

1. ➤ Ensure that the indoor unit cannot extract warm air from the outdoor unit.
2. ➤ Do not hang the outdoor unit onto the indoor unit.
3. ➤ **Please observe:** The condensate formed during dehumidification may not be pumped to the outdoor unit as otherwise it will be dissipated back into the air in the room or may run out of the outdoor unit.
4. ➤ Take the condensate drain hose on the back of the indoor unit out of its bracket and remove the plug.
5. ➤ Allow the condensate to drain downwards into a drain or container.

### ! NOTICE!

Ensure that the external container does not overflow. This could result in water damage.

6. ➤ Switch the unit on by means of the "I / 0" button.
7. ➤ Set the temperature selection switch to the lowest nominal temperature.
8. ➤ Use the "MODE" key to adjust the dehumidification mode. The fan speed is set automatically.

## 5 Installation

### Installation instructions

The device is supplied in a fully operational condition and is equipped as standard with a 3.0 m long connection pipe linking the indoor and outdoor devices, meaning that it is ready for use. The scope of delivery includes various accessories for mounting the outdoor unit.

### Indoor unit

The indoor unit is positioned at the desired location with the air discharge side pointing into the room. When positioning, ensure there is a minimum gap of 20 cm around the device.

### Connector pipes

The connector pipes can be laid through a tilted window or through a gap in the door. The connector pipes can be optionally disconnected from the indoor unit for stationary installation and therefore guided through a wall opening (at least 60 mm). An authorised specialist company is required for this. Please note the following information when laying the connector pipes:

- The connector pipes may not be jammed in or kinked.
- There may not be any tension or other mechanical stress exerted on the connector pipes.
- The pipe insulation and the protective jacket may not be damaged.

### Outdoor unit

The outdoor unit expels the heat from the room into the outside air. In order to do so, the outdoor unit should be positioned vertically and protected from direct sunlight. A minimum gap of 20 cm should be maintained from the air discharge side to the wall. It must be ensured that the air can be discharged freely (min. 50 cm gap to any obstacles). The connecting pipe is fed through a gap in the window (Fig. 5) or door (Fig. 7).

### Installation on the ground

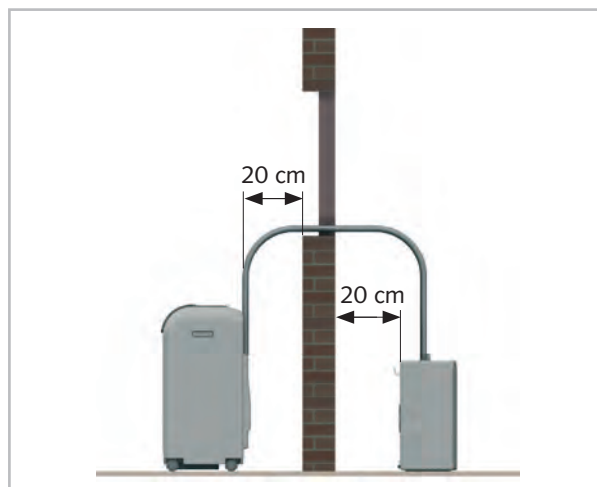

Fig. 5: Minimum clearance to wall

It is not necessary to use any mounting accessories when installing the outdoor unit on a patio or balcony. The outdoor unit should be positioned vertically and protected from direct sunlight. A minimum gap of 20 cm should be maintained from the air discharge side to the wall. It must be ensured that the air can be discharged freely (min. 50 cm gap to any obstacles). The connecting pipe is fed through a gap in the window (Fig. 5) or door (Fig. 7).



Fig. 6: Absence of minimum gap

# REMKO RKL DC series

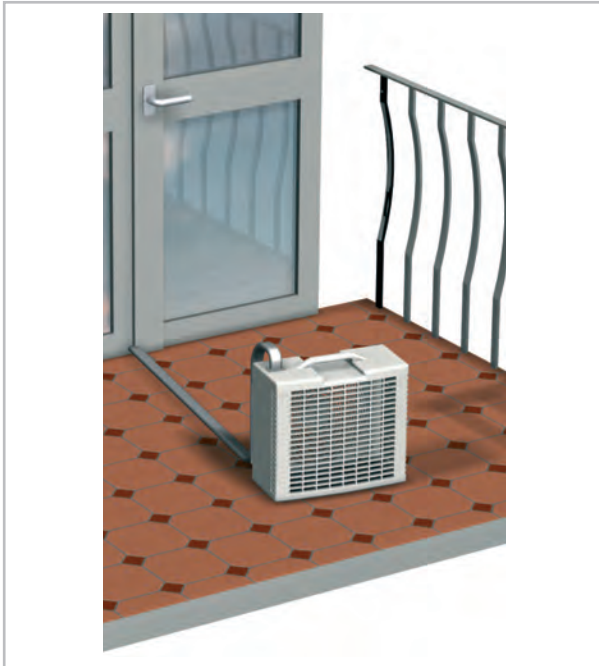

Fig. 7: Example assembly outdoor unit

## Mounting on an external wall with wall bracket

- Fasten to the wall using the supplied wall bracket.
- Hook the outdoor unit into the wall bracket and secure it with the supplied M4 bolts (Fig. 8 and Fig. 9).

The wall brackets can be fastened with the supplied fastening elements (dowel 6mm and screws).

Should this not be suitable for the characteristics of the wall then the fastening elements should be selected on site to ensure suitable holding force. When mounting, ensure that the cable is not stressed and that the insulation is not damaged in the process. Maintain the minimum gaps. The air outlets of the indoor and outdoor units may not be blocked.

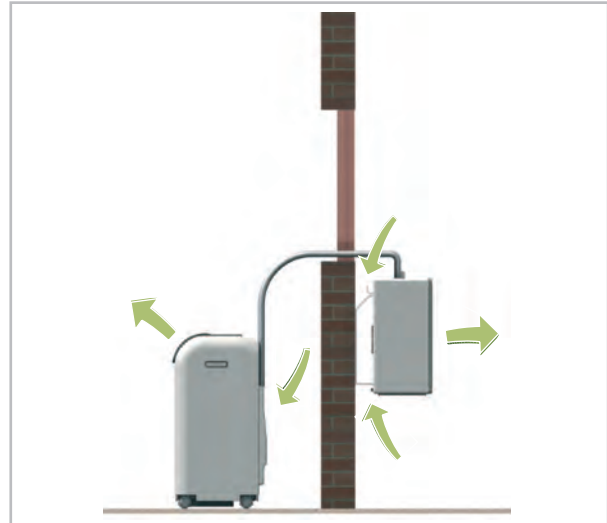

Fig. 8: Required air circulation

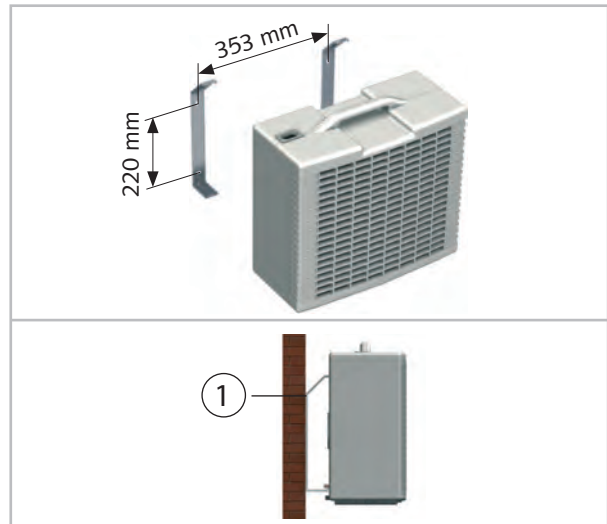

Fig. 9: Gaps assembly bracket

- 1 Safety bolt M4

## Mounting height

The outdoor unit (lower edge) may only be mounted max. 1.8 m above the installation level of the indoor unit (Fig. 10). If the outdoor unit is mounted below the installation level of the indoor unit, then the height difference may not exceed 1.5 m.

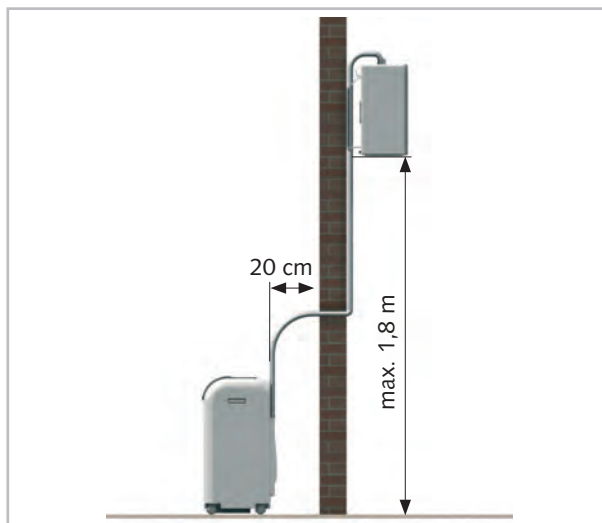

Fig. 10: Max. assembly height

### External wall mounting with fastening straps

Fastening straps are an additional option for mounting the outdoor unit to an external wall or parapet wall.

- Hook the wall bracket onto the outdoor unit and secure it with the screws (M4).
- Hook one end of the fastening strap with the spring catch into the fastening eyelet of the outdoor unit.
- Hook the other end of the fastening strap into the eyelet bolt which is to be attached to the on-site external wall or parapet wall (Fig. 11). Ensure sufficient stability.

### ! NOTICE!

Depending on the weather can out of the condensate drain at the back of the outer part condensation run and cause noise. This is a normal process. Select the installation site for the outdoor unit in such a way as the draining water cannot cause any form of damage or hook up the connection to a drain.

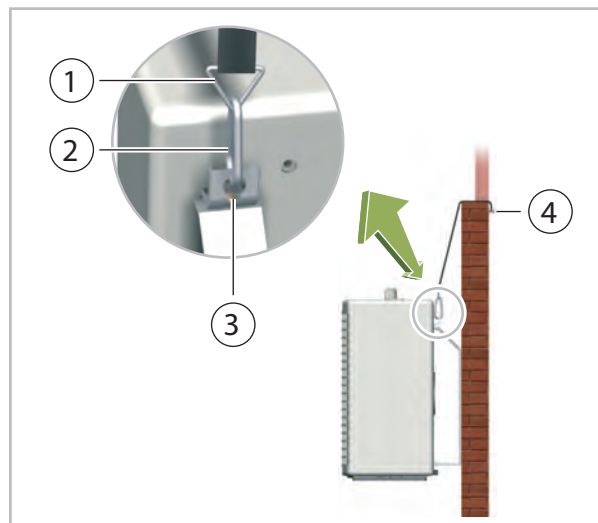

Fig. 11: Assembly with fastening straps

- 1 Spring catch
- 2 Fastening eyelet
- 3 Safety bolt M4
- 4 Eyebolt

# REMKO RKL DC series

## 6 Connecting line

The connecting line is connected to the outdoor unit in the factory with quick-release couplings. This facilitates disconnection of the connecting line from the outdoor unit for assembly purposes without losing refrigerant.

### DANGER!

The unit must be disconnected from the mains supply during the entire process! It may only be switched back on when all of the connections have been made and checked. The fastenings and all of the covers must be attached beforehand.

### DANGER!

Suitable protective gear must be worn when connecting or disconnecting the connection pipe.

### NOTICE!

The escape of refrigerant contributes to climatic change. In the event of escape, refrigerant with a low greenhouse potential has a lesser impact on global warming than those with a high greenhouse potential.

This unit contains refrigerant with a greenhouse potential of 675. That means the escape of 1 kg of this refrigerant has an effect on global warming that is 675 times greater than 1 kg CO<sub>2</sub>, based on 100 years. Do not conduct any work on the refrigerant circuit or dismantle the unit - always enlist the help of qualified experts.

### Instructions for disconnecting the connecting line:

- Disconnect the units only immediately before assembly and only leave the units disconnected for as long as is absolutely necessary.
- Before the pipes are reconnected, it is to be ensured that there is no dirt, moisture or other foreign bodies in the quick release couplings which could impair their function.
- Always mount the fastening clip as soon as the lines are connected.
- The pipelines may only be disconnected and connected by authorised specialist engineers.

In doing so, the following procedure must be adhered to:

1. ➤ Switch the unit off.
2. ➤ Pull the power plug out of the socket.
3. ➤ Remove the 2 screws from the cover on the rear side of the outdoor unit (Fig. 12).

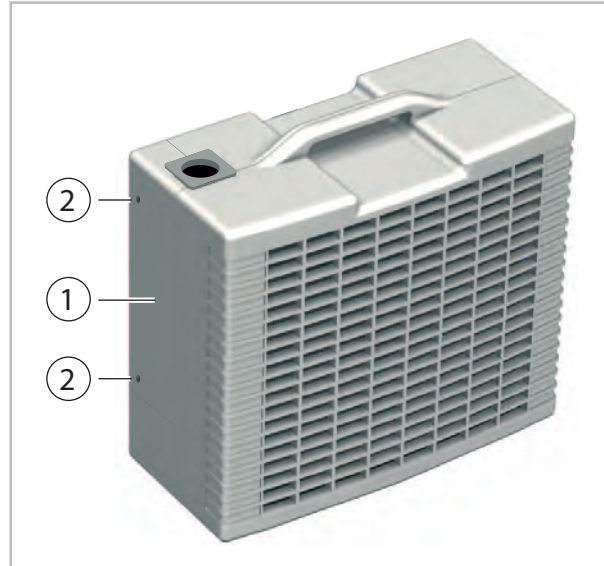

Fig. 12: Remove cover

- 1: Cover
- 2: Screws

4. ➤ Remove the cover from the unit.
5. ➤ Loosen the 2 screws of the strain relief and remove them.

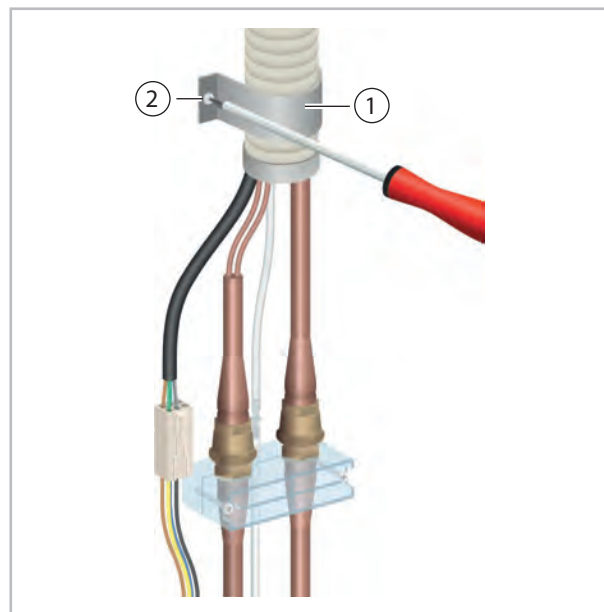

Fig. 13: Removing the strain relief

- 1: Strain relief / 2: Screws

6. → Press on the locking hook of the plug connection and pull the plug connection apart.

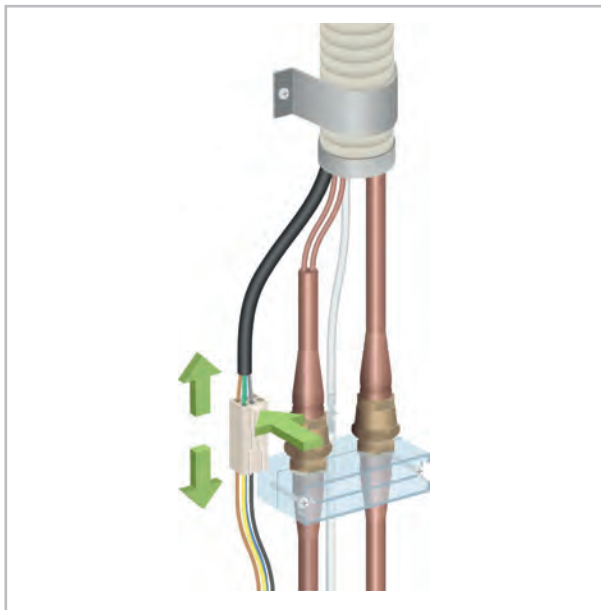

Fig. 14: Disconnecting the plug connection

7. → Pull the condensate hose apart at the connection point.

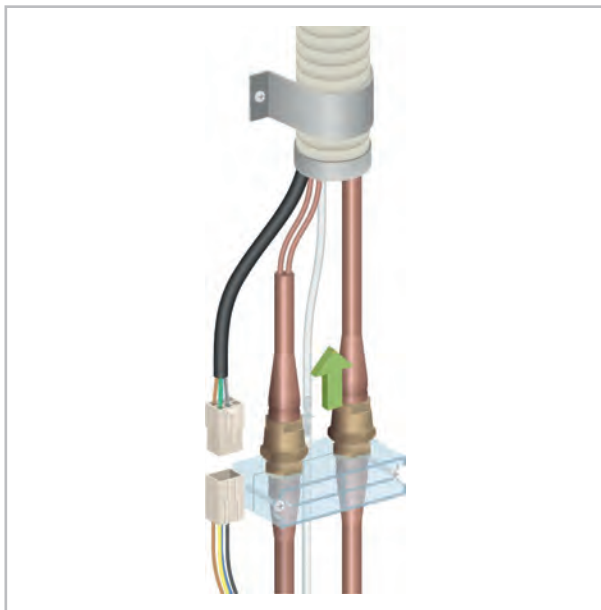

Fig. 15: Disconnecting the condensate hose

8. → Remove the upper section from the bracket by means of unscrewing the two screws.

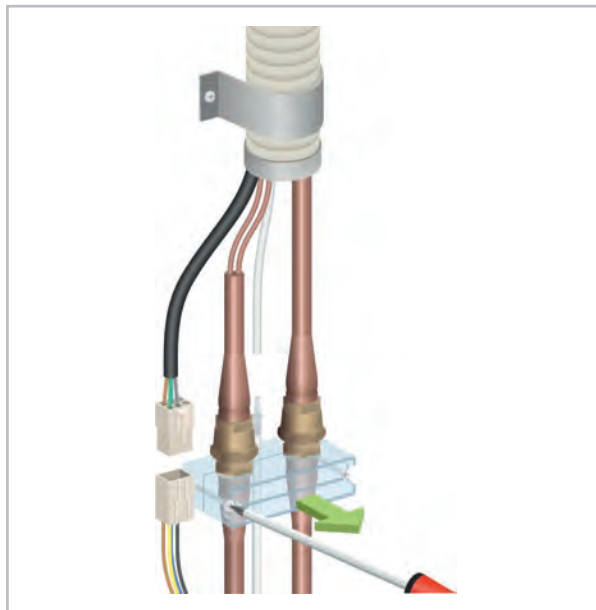

Fig. 16: Removing the bracket

9. → Unscrew the left-hand union nut with the size 24 open-ended spanner provided. In doing so, use the second size 21 open-ended spanner to hold the upper coupling section still.

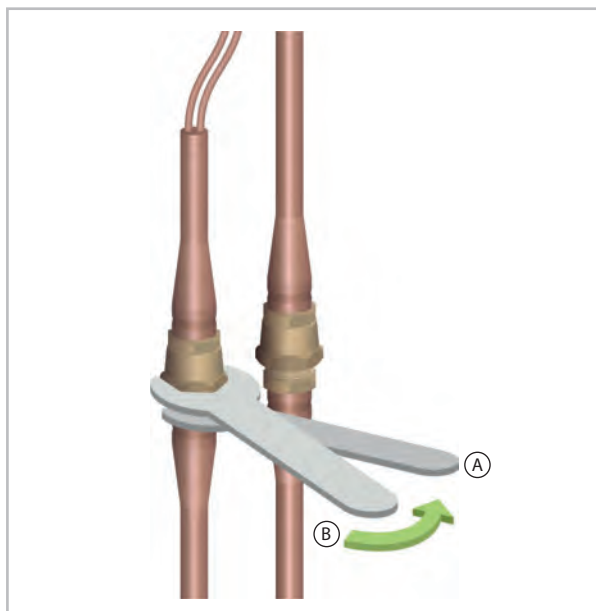

Fig. 17: Unscrewing the left-hand union nut

- A: Hold to prevent turning  
B: Loosen

10. → Screw continuously until the connection is disconnected.

# REMKO RKL DC series

**! NOTICE!**

Never twist the the fixed lower section.

**! NOTICE!**

It is possible that residual fluid can leak out of the the condensate hose.

- 11.** ► Unscrew the right-hand union nut with the size 24 open-ended spanner provided. In doing so, use the second size 21 open-ended spanner to hold the lower coupling section still.

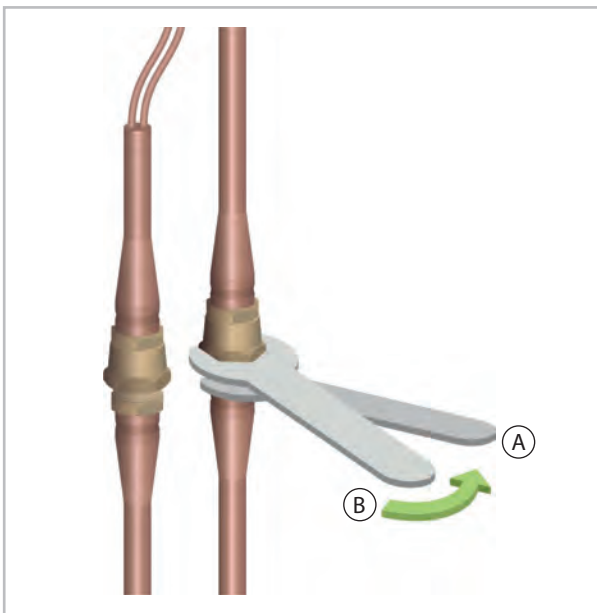

Fig. 18: Unscrewing the right-hand union nut

- A: Hold to prevent turning  
B: Loosen

- 12.** ► Screw continuously until the connection is disconnected.

**! NOTICE!**

Never twist the the fixed lower section.

**! NOTICE!**

Do not stop screwing in the event that refrigerant escapes and a slight hissing sound is heard.

- 13.** ► Ensure that there is a wall opening available of  $\varnothing$  60 mm in the event that the connecting line is to be fed through a wall.

- 14.** ► After the placement or mounting of the indoor unit and outdoor unit is complete, the connecting line can be hooked up to the outdoor unit in the opposite order.

- 15.** ► After making the connections, check the quick-release couplings for leaks.



## 7 Electrical wiring

### Electrical wiring diagram

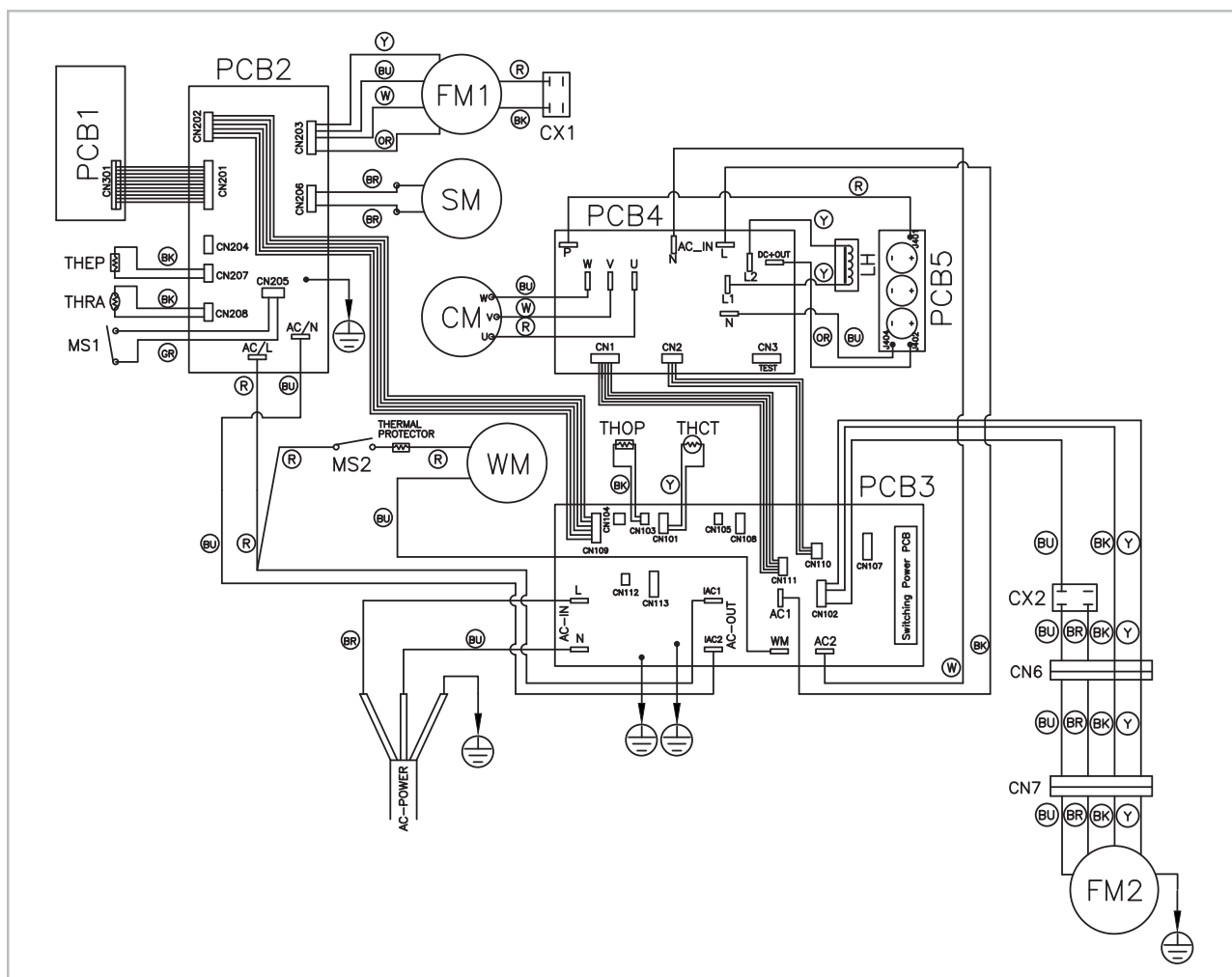

Fig. 19: Electrical wiring diagram

PCB1:	Keypad board	THCT:	Compressor temperature probe
PCB2:	Control board	THEP:	Probe, evaporator
PCB3:	Motherboard	THOP:	Compressor end temperature probe
PCB4:	IPM protection board	THRA:	Room temperature probe
PCB5:	Capacitor board	WM:	Condensate pump
CM:	Compressor	Colour coding:	
CX1:	Capacitor, evaporator fan	BK:	black
CX2:	Capacitor, condenser fan	BR:	brown
FM1:	Evaporator fan	BU:	blue
FM2:	Condenser fan	GR:	grey
LH:	Reactor	OR:	orange
MS1:	Microswitch malfunction, (container full)	R:	red
MS2:	Microswitch condensate pump	W:	white
SM:	Swing motor	Y:	yellow

# REMKO RKL DC series

## 8 Troubleshooting

The unit has been manufactured using state-of-the-art production methods and has been tested several times to ensure that it works properly. If malfunctions should occur, please check the unit as detailed in the list below. Please inform your dealer if the unit is still not working correctly after all the function checks have been performed.

### Operational malfunctions

Fault description	Cause	Remedy
The unit does not start	Power failure	Check voltage and if necessary wait until turned on again
	Mains fuse or controller fuse faulty	Arrange to have exchanged
	Power plug not inserted in socket	Insert power plug
	Condensate container full, "DRAIN WATER" display flashes	Empty container via the condensate drain hose
	Timer mode activated	Wait for timer period to expire or press "I / O" key again
The unit is working with reduced performance	Exhaust air or outlet openings are dirty or blocked by foreign bodies	Clean the openings, remove foreign bodies
	Filter soiled	Clean the filter in accordance with the instructions
	Outdoor unit soiled	Clean the fins on the inside of the outdoor unit
	Cooling load of the room excessive	Reduce the thermal load
Condensate leaks out of unit	Unit standing at an angle	Position vertically, ensure stable base
	Stopper in condensate drain hose missing	Seal the hose so that it is watertight again

### Error indication by code

If the following alarm codes appear, please contact your dealer:

Error code	Error description	Possible cause/remedy
01#	Communication error between the circuit board on the indoor unit and outdoor unit	- Check the 6-wire connection and plug contacts CN202 (PCB 2) - CN109 (PCB 3). Replace the connecting cable if necessary. - Replace the motherboard (PCB 3)
02#	Ambient temperature probe defective	- Replace THRA probe (PCB 2)
03#	Probe, evaporator defective	- Replace THEP probe (PCB 2)

Error code	Error description	Possible cause/remedy
32#	Liquid line probe defective Liquid line excessive temperature	- If the error appears <1 minute after turning on the unit, the THOP probe (PCB 3) is defective. Replace it. - If the error only appears after operating for some time, a lack of refrigerant can be the cause or the fan motor of the outdoor unit is not working properly. If the temperature on the THOP probe rises above 58 °C, the unit switches off and error code "32" appears on the display.
33#	Compressor probe defective	- THCT temperature sensor (PCB 3) defective. Replace the probe. - Is there an excessive temperature on the compressor or is the outside temperature too high? Is the outdoor unit fan motor working properly?
35#	Speed control of the compressor faulty	- Compressor possibly defective - Replace the IPM circuit board (PCB 4).
36#	Heat gas temperature on the compressor too high	Compressor defective? - Is there an excessive temperature on the compressor or is the outside temperature too high? Is the outdoor unit fan motor working properly?
37#	Liquid line temperature too high	- see error code 32
38#	AC voltage on motherboard (PCB 3) too low. Transformer on circuit board not OK.	- Replace motherboard (PCB 3)
39#	AC voltage on motherboard (PCB 3) too high. Transformer on circuit board not OK.	- Replace motherboard (PCB 3)
40#	Motherboard current consumption faulty	- Replace motherboard (PCB 3)
41#	IPM circuit board communication error	Check the 5-wire connecting line and contacts CN1 (PCB 4) - CN111 (PCB 3) and CN2 (PCB 4) - CN110 (PCB 3).
42#	IPM circuit board defective	- Replace IPM circuit board
43#	Overvoltage (DC) on IPM circuit board	- Replace IPM circuit board
44#	IPM module current consumption faulty	- Replace IPM circuit board
45#	Power supply too high or low	- Check the electrical power supply
46#	General IPM error	- Replace IPM circuit board
47#	PFC module on IPM circuit board defective	- Replace IPM circuit board

# REMKO RKL DC series

## 9 Care and maintenance

Regular care and observation of some basic points will ensure trouble-free operation and a long service life of the unit.

The device should be checked and thoroughly cleaned after each prolonged use, but in any case at least once per year.

The entire plant may only be maintained or repaired by specialist authorised firms.

### DANGER!

Prior to performing any work, ensure the equipment is disconnected from the voltage supply and secured to prevent accidental switch-on!



Fig. 20: Remove filter

1 Filter

- Clean the equipment using a damp cloth. Do not use a jet of water.
- Do not use any caustic, abrasive or solvent-based cleaning products.
- Only use suitable cleaning agents, even in the event of severe soiling.
- Empty the condensate container and check if the diameter of the condensate lines have tapered as a result of soiling prior to and after each operating season. If this is the case, they must be cleaned.

### NOTICE!

Check the level of dirt on the on the exchanger fins.

- Clean the air filter on the indoor unit at regular intervals, and more frequently if necessary.
- It is recommended that you take out a maintenance contract with an appropriate specialist firm.



*This enables you to ensure the operational reliability of the plant at all times!*

### NOTICE!

Never operate the indoor unit without the original filter. The heat exchanger fins on the indoor unit with soil up if operated without a filter and the device will suffer performance loss.

### Air filter for indoor unit

Clean the air filter at intervals of no more than 2 weeks. Reduce this interval if the air is especially dirty.

### Cleaning the filter on the indoor unit

Please proceed as follows in order to clean the unit:

1. ➤ Remove the mains plug.
2. ➤ Pull the filter out of the unit (Fig. 20).
3. ➤ Clean the filter of dust. Use a vacuum cleaner in the event of slight soiling.
4. ➤ In the event of more severe soiling, carefully clean in lukewarm water.
5. ➤ Subsequently allow the filter to dry in the air.
6. ➤ Insert the filter back into the device.

## 10 Shutdown

### ! NOTICE!

Never switch off the equipment by pulling out the mains plug.

### Temporary shutdown

If it is planned to shut down the unit for longer periods e.g. during the winter, proceed as follows:

1. ➤ Let the unit run for 2-3 hours in circulation mode. This extracts any residual humidity from the unit.
2. ➤ Put the unit out of operation by pressing the "I / O" key on the operating panel. Only then should you pull out the mains power plug and wind up the cable.
3. ➤ Drain the internal condensation tank through the condensation drainage hose at the rear of the indoor unit.
4. ➤ Make sure that there is no condensate water in the outdoor unit before storing the indoor and outdoor unit indoors. To drain the condensate water, remove the stopper from the outdoor unit.

### ! NOTICE!

If indoor storage is not possible through the winter due to the fixed installation method, the outdoor unit can remain installed outdoors even in frosty conditions. Note that in doing so, all condensate must be removed from the condenser and this must be protected from the influences of the winter weather with a tarpaulin or film sheeting before the winter sets in. However, never operate the unit when the outside temperature is  $< 5^{\circ}\text{C}$ .

(see application area technical data!)

5. ➤ Clean the filter and the plastic surfaces.
6. ➤ Attach the outdoor unit to the indoor unit.
7. ➤ Cover the unit with a synthetic tarpaulin to protect it against dust.
8. ➤ Store the unit in a cool and dry location away from direct sunlight.

### Permanent shutdown

The entire system should only be dismantled by a specialist firm familiar with all environmental aspects involved. REMKO GmbH & Co. KG or your contractual partner will be pleased to provide a list of refrigerant specialists in your area.

# REMKO RKL DC series

## 11 Exploded view and spare parts lists

### 11.1 Exploded view indoor unit

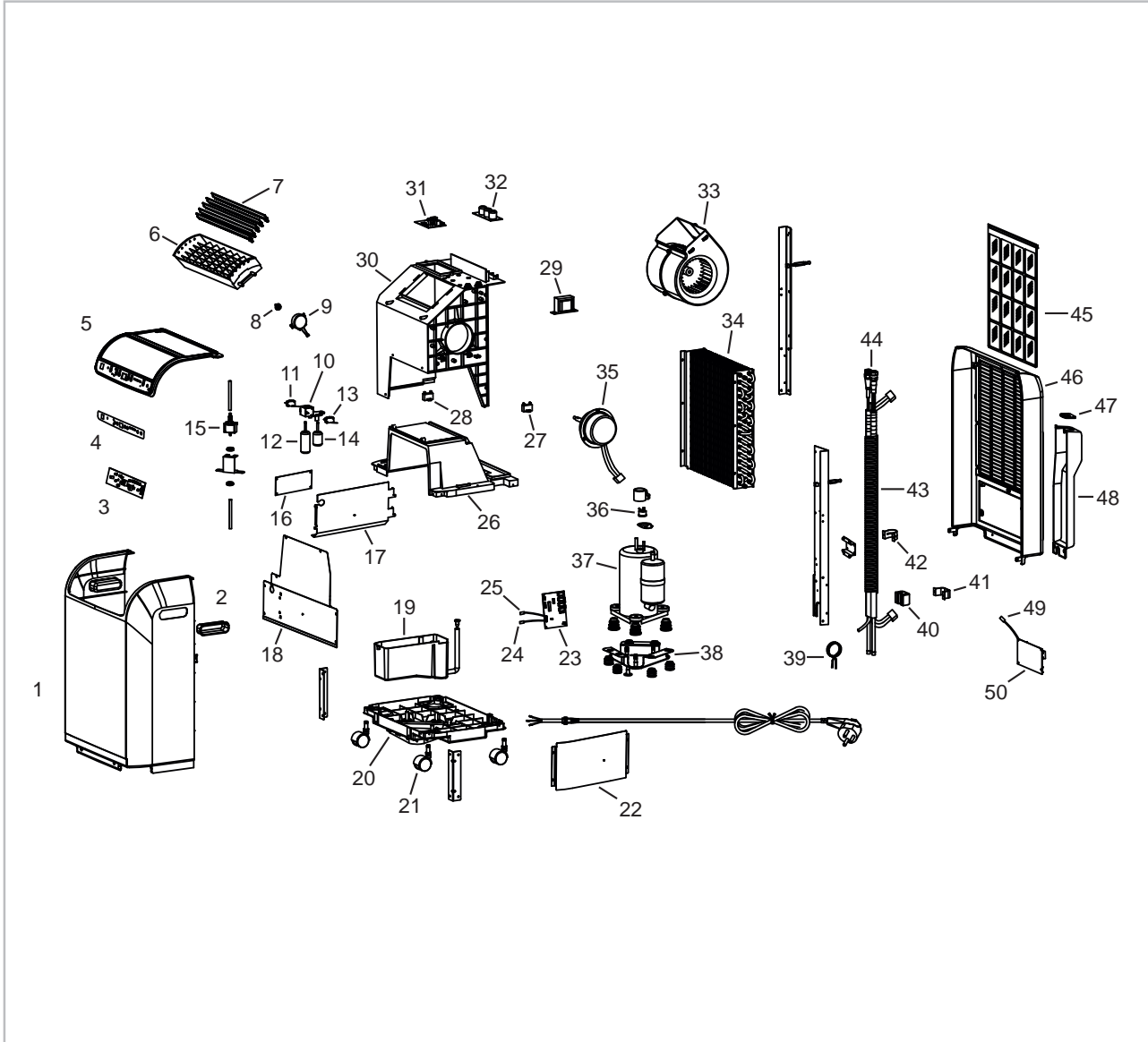

Fig. 21: Exploded view indoor unit

We reserve the right to modify the dimensions and design as part of the ongoing technical development process.

## 11.2 Spare parts list - Indoor unit

Please contact REMKO GmbH & Co. KG directly to order spare parts.



### **IMPORTANT!**

To ensure the correct delivery of spare parts, please always the device type with the corresponding serial number (see type plate)

No.	Designation	RKL 495 DC	RKL 495 DC <i>S-LINE</i>
1	Front wall		
2	Recessed grip		
3	Keypad board		
4	Keypad foil		
5	Cover, top		
6	Exhaust grille		
7	Ventilation louvres		
8	Coupling for swing motor		
9	Swing motor for fins		
10	Bracket for microswitch		
11	Microswitch, pump		
12	Float, pump		
13	Microswitch, container full		
14	Float, container full		
15	Condensate pump		
16	Sound absorption mat		
17	Sound absorption sheet, inside		
18	Sound absorption sheet, front		
19	Condensate container		
20	Unit base		
21	Conveyor rollers		
22	Sound absorption sheet, right		
23	Motherboard		
24	Room temperature probe		
25	Probe, evaporator		
26	Partition wall		
27	Capacitor, condenser fan		
28	Capacitor, evaporator fan		
29	Choke		
30	Covering on fan		

On request by providing the serial number

# REMKO RKL DC series

No.	Designation	RKL 495 DC	RKL 495 DC <i>S-LINE</i>
31	IPM protection board	On request by providing the serial number	
32	Capacitor board		
33	Evaporator fan, complete		
34	Evaporator		
35	Fan motor, evaporator		
36	Overheating protection for compressor		
37	Compressor, cpl.		
38	Base plate, cpl.		
39	Capillary tube		
40	Seal fastening clip		
41	Pipe fastening clip		
42	Sheath fastening clip		
43	Connecting line		
44	Coupling, set		
45	Recirculated air filter		
46	Back wall		
47	Connecting line opening		
48	Cover for connecting line		
49	Compressor end temperature probe		
50	Control board		



### 11.3 Exploded view - Outdoor unit

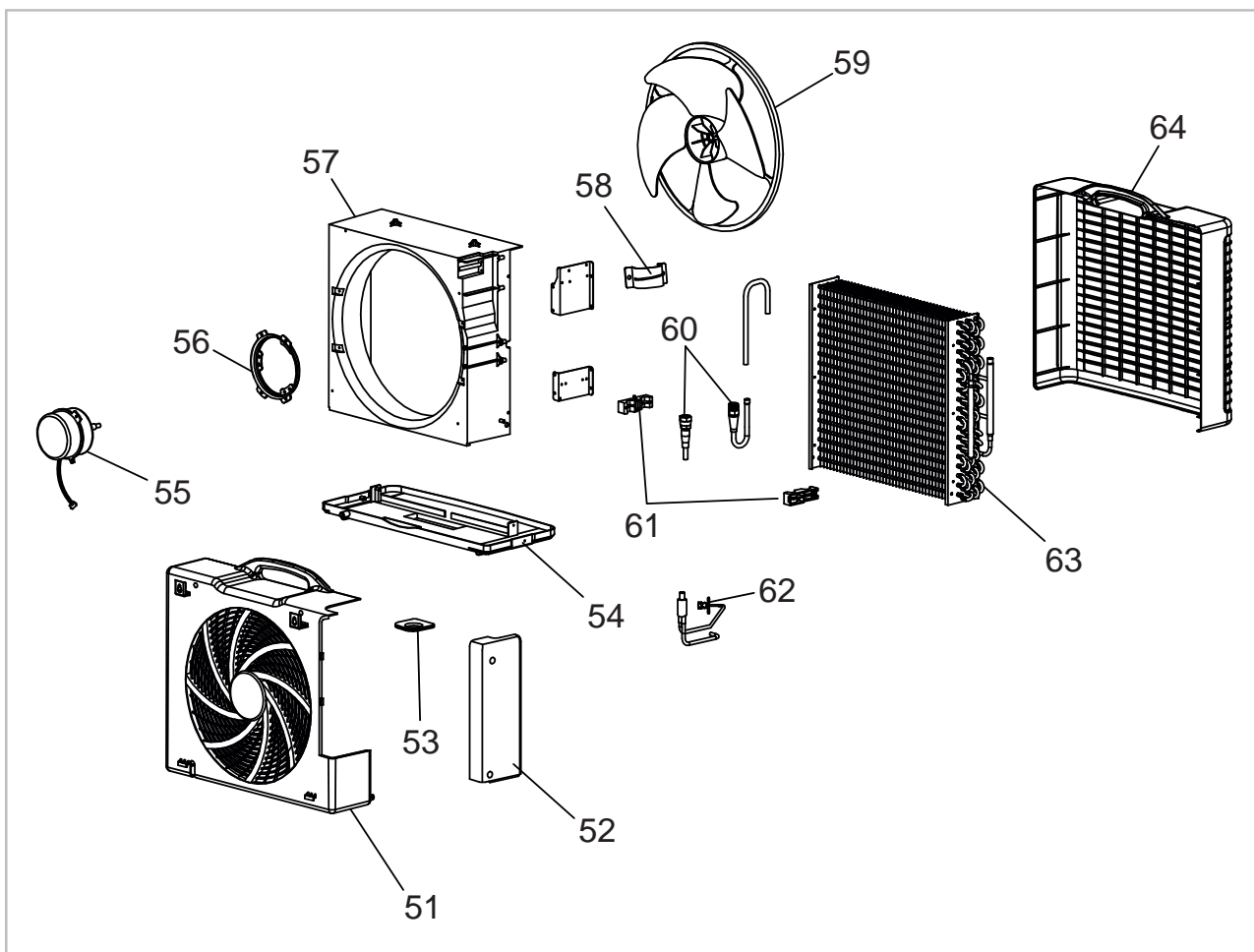

Fig. 22: Exploded view outdoor unit

We reserve the right to modify the dimensions and design as part of the ongoing technical development process.

# REMKO RKL DC series

## 11.4 Spare parts list - Outdoor unit

No.	Designation	RKL 495 DC	RKL 495 DC <i>S-LINE</i>
51	Back wall	On request by providing the serial number	
52	Threaded fittings for cover		
53	Connecting line opening		
54	Unit base		
55	Fan motor, condenser		
56	Fan motor fastening		
57	Fan covering		
58	Sheath fastening clip		
59	Condenser fan		
60	Coupling, set		
61	Coupling fastening clip		
62	Service connection		
63	Condenser		
64	Front wall		
<b>Spare parts not illustrated</b>			
	Remote control	On request by providing the serial number	
	Fastening set for outdoor unit, cpl.		
	Connector condensate drainage line		
	Wall bracket		

When ordering spare parts, please quote the serial no., unit number and unit type (see name plate)!

## 12 Index

### A

Assembly	
Connecting line	14

### C

Care and maintenance	20
----------------------	----

### D

Disposal of equipment	6
-----------------------	---

### E

Electrical wiring diagram	17
Environmental protection	6
Exploded view drawing	
Indoor unit	22
Outdoor unit	25

### F

Filter cleaning	20
-----------------	----

### I

Installation	
Connector pipes	11
External wall mounting with fastening straps	
	13
Indoor unit	11
Installation on the ground	11
Mounting height	12
Mounting on an external wall with wall bracket	12

Outdoor unit	11
--------------	----

### M

Maintenance	20
-------------	----

### O

Operation	
Circulated air mode	10
Control panel	9
Cooling mode	10
Dehumidifying mode	10

### S

Safety	
Dangers of failure to observe the safety notes	5
General	4
Identification of notes	4
Instructions for the operator	5
Note for inspection work	5
Note for installation work	5
Note for maintenance work	5
Personnel qualifications	4
Safety-conscious working	5
Unauthorised modification	6
Unauthorised replacement part manufacture	6

### W

Warranty	6
----------	---

# REMKO QUALITY WITH SYSTEMS

Air-Conditioning | Heating | New Energies

**REMKO GmbH & Co. KG**  
**Klima- und Wärmetechnik**

Im Seelenkamp 12  
32791 Lage

Telephone +49 (0) 5232 606-0  
Telefax +49 (0) 5232 606-260

E-mail [info@remko.de](mailto:info@remko.de)  
URL [www.remko.de](http://www.remko.de)

**Hotline within Germany**  
+49 (0) 5232 606-0

**Hotline International**  
+49 (0) 5232 606-130

